

8

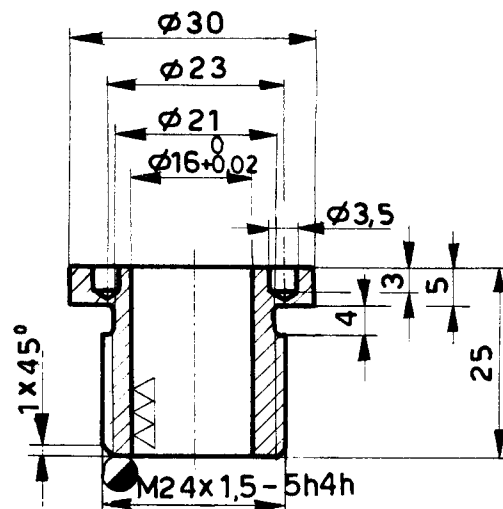

5

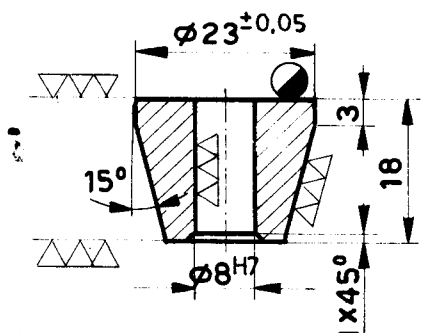

14

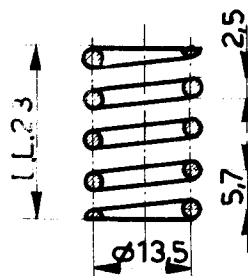

13

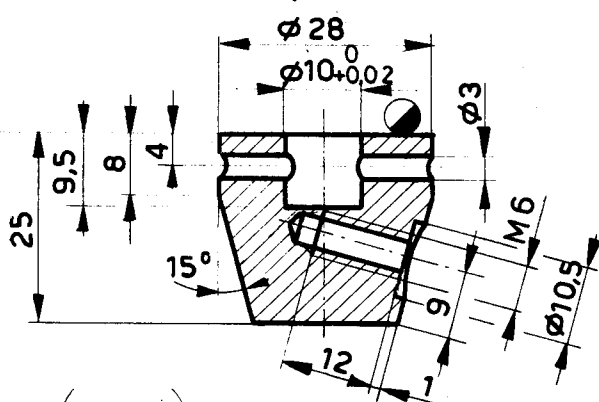

10

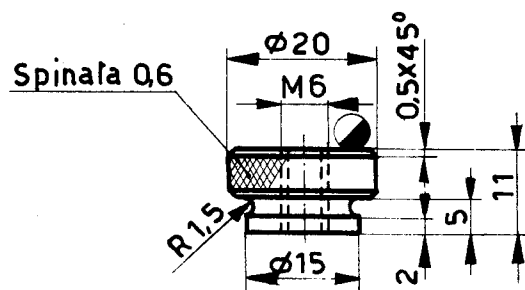

15

15	DADO	1	∅25 x 25	C	10
14	CONO	1	∅25 x 35	C	10
10	TESTA	1	∅32 x 40	C	10
13	MOLLA	1	∅2,5 x 185	C	72
8	BOCCOLA	1	∅38 x 55	C	10
5	BRONZINA	2	∅32 x 40	B	17

POS.	DENOMINAZIONE	QUANT.	DIMENS. GREZZO	MATERIALE	NOTE
------	---------------	--------	----------------	-----------	------

TOLLERANZE	TEMPO CONCESSO	SCALA 1:1	
ESERCIZIO PROPOSTO DA			